

# GL105M1 1

## 5-Dots Array LED, Dichromatic (3 yellow-green dots and 2 red dots)

■ Model No.

**GL105M11** Yellow-green GaP  
Red GaP

■ Features

1. Radiation shape per dots 2.0 × 5.0mm
2. Outline dimensions 7.0 × 40.0mm
3. 5 dots case mold type
4. Yellow-green : 3 dots
5. Red : 2 dots

■ Outline Dimensions

(Unit: mm)

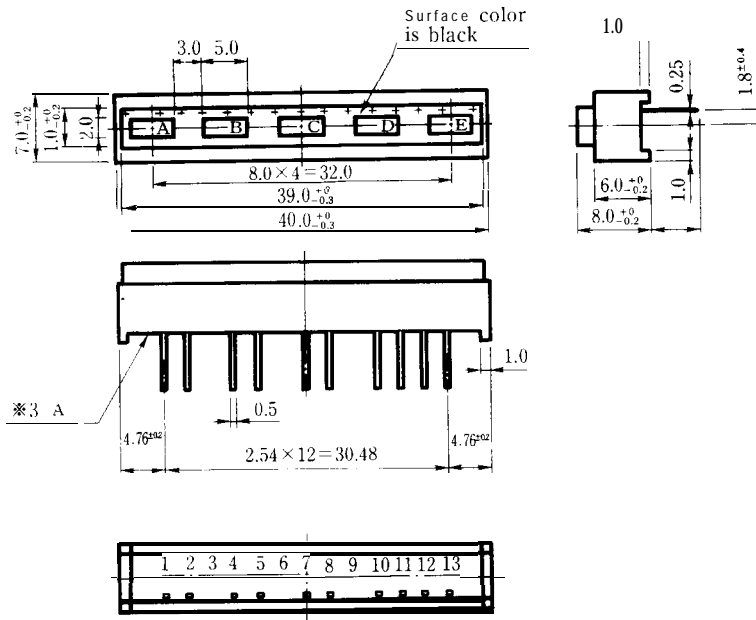

Internal connection diagram

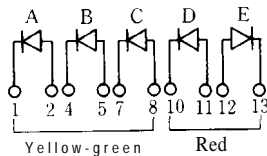

Unspecified tolerance : ±0.38mm

7

## GL105M1 1

## ■ Absolute Maximum Ratings \*1

(Ta = 25°C)

Parameter	Symbol	GL105M11				Unit	
		Yellow-green	Red				
Power dissipation	P	38	25			mW	
Continuous forward current	I <sub>F</sub>	15	10			mA	
*2 Peak forward current	I <sub>FM</sub>	50	<b>50</b>			mA	
Derating factor	DC	—	0.27	0.18		mA/°C	
	Pulse	-	0.91	0.91		mA/°C	
Reverse voltage	V <sub>R</sub>	5	5			V	
Operating temperature	T <sub>opr</sub>	-20 to +70				°C	
Storage temperature	T <sub>stg</sub>	-30 to +80				°C	
*3 Soldering temperature	T <sub>sol</sub>	260 (within 5 seconds)					°C

\*1 Per dot

\*2 Duty ratio= 1/10, Pulse width =0.1ms

\*3 At the position of 2.6 mm from (A) level of outline dimensions

GL105M1 1 (Yellow-green/Red)

■ Electro-optical Characteristics ※ 1

(Ta = 25°C)

Parameter	Symbol	Radiation color	Conditions	MIN.	TYP.	MAX.	Unit
Forward voltage	V <sub>F</sub>	Yellow-green	I <sub>F</sub> = 10mA	—	2.0	2.5	v
		Red	I <sub>F</sub> = 5mA	—	1.9	2.5	
※4 Luminous intensity	I <sub>v</sub>	Yellow-green	I <sub>F</sub> = 10mA	0.2	0.5	—	mcd
		Red	I <sub>F</sub> = 5mA	0.15	0.3	—	
Peak emission wavelength	λ <sub>p</sub>	Yellow-green	I <sub>F</sub> = 10mA	—	565	—	‘m
		Red	I <sub>F</sub> = 5mA	—	695	—	
Spectrum radiation bandwidth	Δλ	Yellow-green	I <sub>F</sub> = 10mA	—	30	—	‘m
		Red	I <sub>F</sub> = 5mA	—	100	—	
Reverse current	I <sub>R</sub>	Yellow-green	V <sub>R</sub> = 4V	—	—	10	μA
		Red	V <sub>R</sub> = 4V	—	—	10	
Response frequency	f <sub>c</sub>	Yellow-green	—	—	4	—	MHz
		Red	—	—	4	—	

※1 Per dot

※4 Tolerance: ±30%

■ Characteristics Diagrams

Forward current I<sub>F</sub> vs. Forward Voltage (Ta = 25°C)

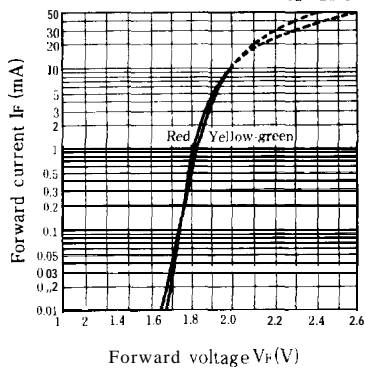

Luminous Intensity vs. Forward Current (Ta = 25°C)

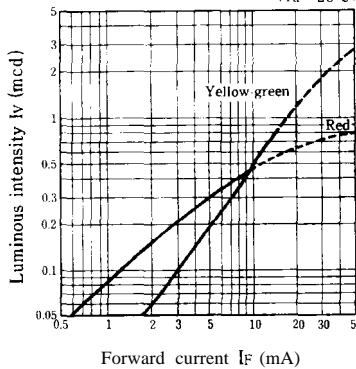

Forward Current Derating Curve

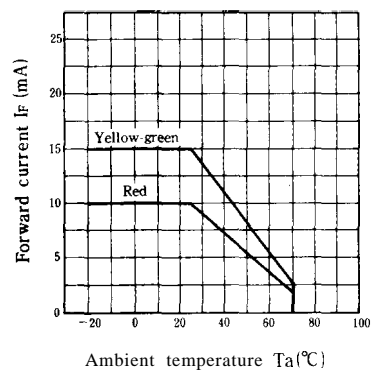

Relative Luminous Intensity vs. Ambient Temperature (Y.G.: I<sub>F</sub> = 10mA, Red: I<sub>F</sub> = 5mA)

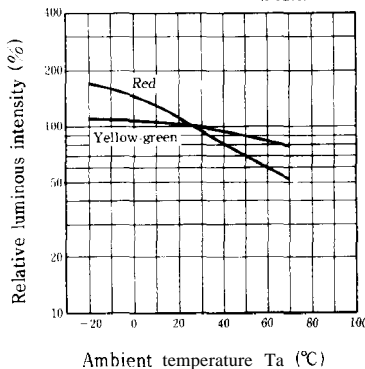

Spectrum Distribution (Ta = 25°C)

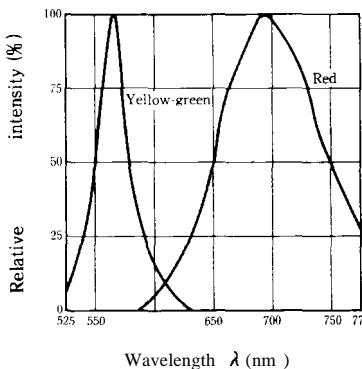

7